

T&B Steel Cable Tray Systems

Cable management **solutions** for industrial facilities





Engineers, contractors and end users involved in the construction and maintenance of industrial facilities need to manage wire and cable logistics effectively without compromising quality, safety, budgets or deadlines.

Thomas & Betts provides a complete steel cable tray package that includes innovative solutions.



Extensive product range

- **Ladder, ventilated and solid tray**
- **Pre-galvanized, hot-dip galvanized steel and stainless steel**
- **Exclusive, CSA-certified, 42-inch width**



Features and products to increase efficiency and reduce costs

- **Alternating strut rung design standard on all T&B ladder tray**
- **Pre-drilled siderails, ready for bonding jumper installation**
- **Innovative splicing and fittings solutions that reduce material and labour costs**
- **High-strength fittings, tested and approved for alternate installation methods with reduced supports**



Local manufacturing, service and support

- **Two manufacturing facilities located in Saint-Jean-sur-Richelieu, Quebec and Edmonton, Alberta**
- **Canadian-based product development and engineering**
- **Local sales and technical support**

Product content for engineering software

- **A range of file formats and content for specific software solutions**
- **Complete details at www.tnb.ca/en/cable-tray-design-tools/**



Complete cable management solutions
for industrial facilities.

Thomas & Betts

A Member of the ABB Group

Start with a complete range of products for industrial applications.



T&B Steel Cable Tray Systems are installed in industrial facilities across Canada and around the world. Designed and manufactured in Canada, our steel cable tray offering includes ladder, ventilated and solid tray in pre-galvanized and hot-dip galvanized steel, as well as stainless steel.

Materials and Finishes for a Full Range of Applications

Steel

- **Pre-galvanized (PG) finish**
For use in dry, indoor environments such as manufacturing plants
- **Hot-dip galvanized (HDG) finish**
For use in more corrosive indoor environments and outdoor applications such as mines, water/wastewater treatment facilities and chemical processing plants

Stainless Steel

- Roll-formed AISI Type 316L low-carbon stainless steel
- For use in highly-corrosive environments such as potash mines, food and beverage processing facilities and applications with high ambient temperatures such as metal foundries

Exclusive Design Features

Special Rung Design

- Extra-wide rung maximizes load-bearing surface, minimizing deflection
- Continuous strut profile rung accepts standard strut accessories
- Alternating rungs facilitate installation of accessories from top or bottom

C-Shape Siderail Profile

- High-strength C-shaped profile resists deformation and protects cables
- Full range of siderail heights – 3-, 4-, 5-, 6- and 7-inches to meet different load and capacity requirements

In addition to standard tray widths of 6, 9, 12, 18, 24, 30 and 36 inches, Thomas & Betts offers an exclusive **CSA-certified, 42-inch width option in both steel and stainless steel.**



Save with innovative solutions that increase installation efficiency and reduce costs.

Pre-drilled Siderail

- Pre-drilled to accept bonding jumper
- Simplifies and speeds up installation
- Standard on all steel ladder tray

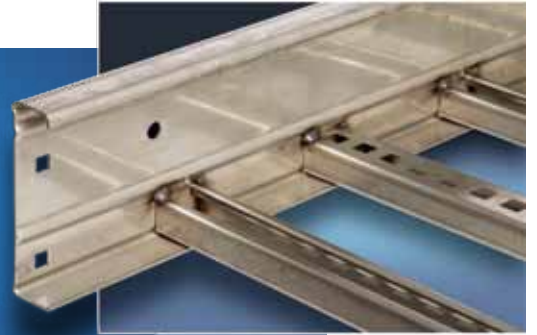

Helix® Fitting

- Simplifies horizontal to vertical and vertical to horizontal transitions
- Minimizes space requirements – no need to distance cable runs from surfaces
- Very large bend radius for cables
- Secures and protects cables within fitting
- Includes integrated splice plates at both extremities



Super-Duty Splice Plate™

- Enables reduction of supports recommended for NEMA standard installations at the expansion joint
- Available in 4-, 5-, 6- and 7-inch siderail heights
- Saves material and labour costs



ADDITIONAL SUPPORTS PER NEMA STANDARD INSTALLATION

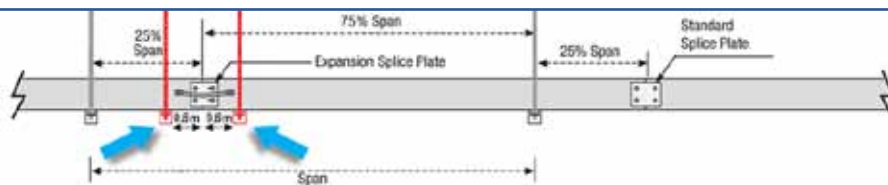

NO ADDITIONAL SUPPORTS NEEDED WITH SUPER-DUTY SPlice PLATE™

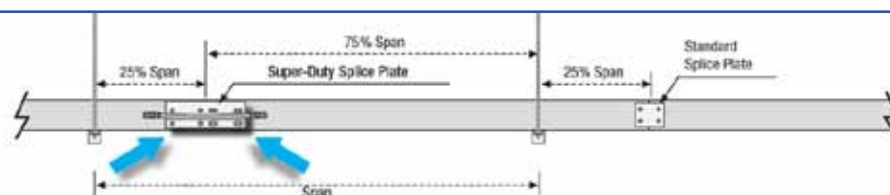

Save even more on support and labour with tested 6-inch siderail fittings for horizontal applications.

Reducing the number of structural steel supports required for cable tray runs is a proven way to significantly reduce material and labour costs.

Extensive testing of our horizontal steel cable tray fittings with a 6-inch siderail (elbows, tees and crosses) demonstrated that either of the following alternatives to NEMA-V2 recommendations for support locations can be used without compromising safety.

Eliminate Fitting Support

maintaining supports at a maximum distance of 24" (610 mm) from the splice

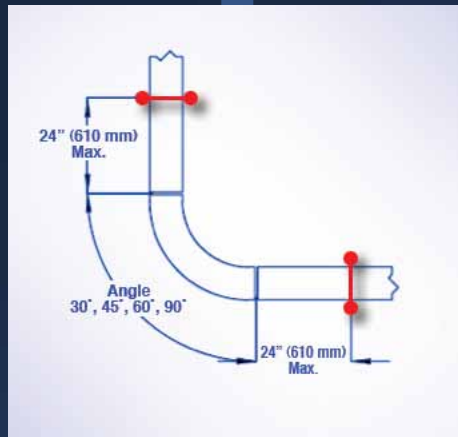

Extend Support Distance

to a maximum distance of 120" (3,048 mm) from the splice

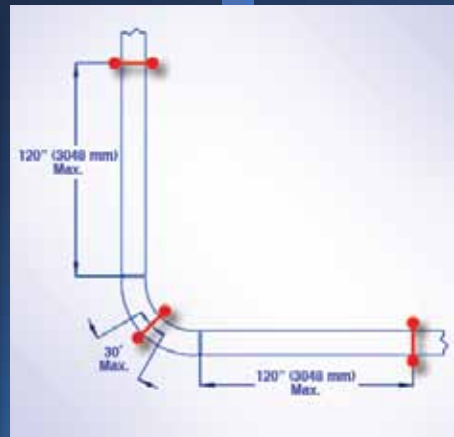

NEMA-V2

Dedicated fitting support, supports at a maximum distance of 24" (610 mm) from the splice

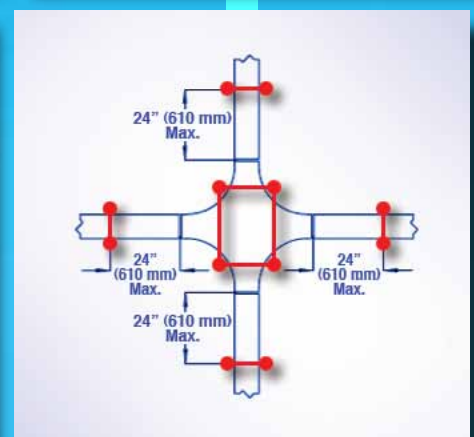
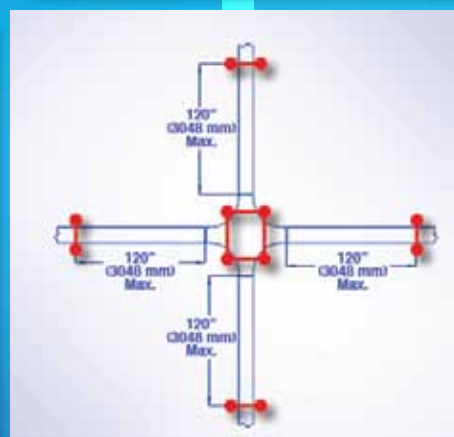
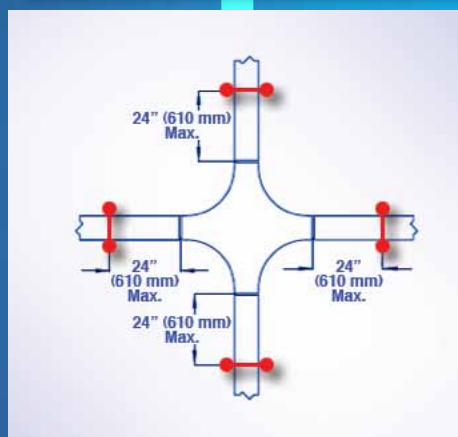
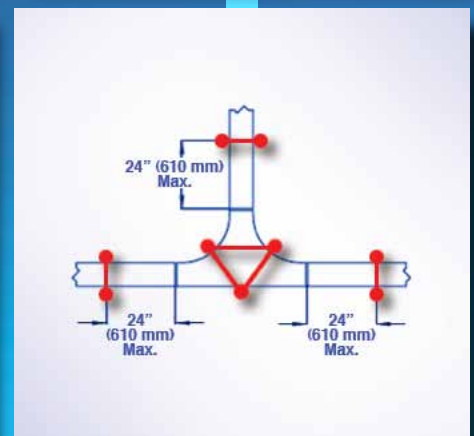
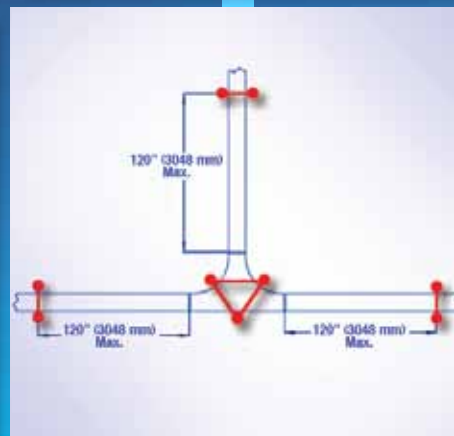
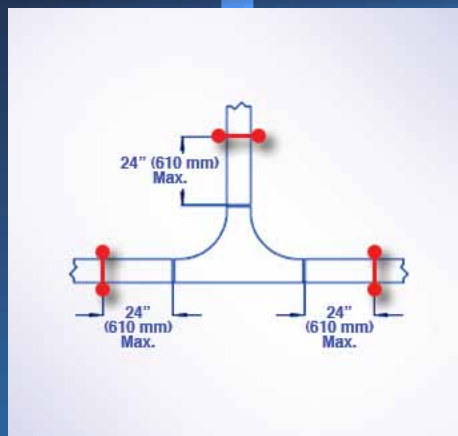
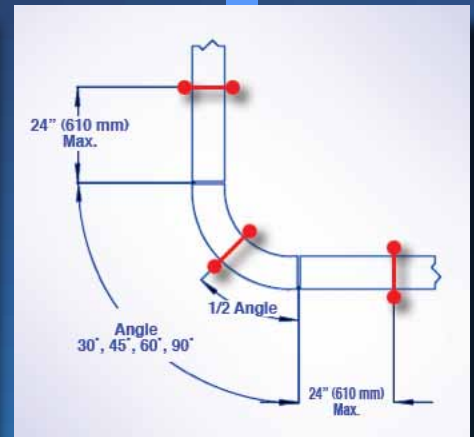

N.B.: Alternatives to NEMA-V2 installation methods approved up to 36-inch radius for horizontal fittings shown above.

Connect with Thomas & Betts

Your best choice for cable management **solutions**

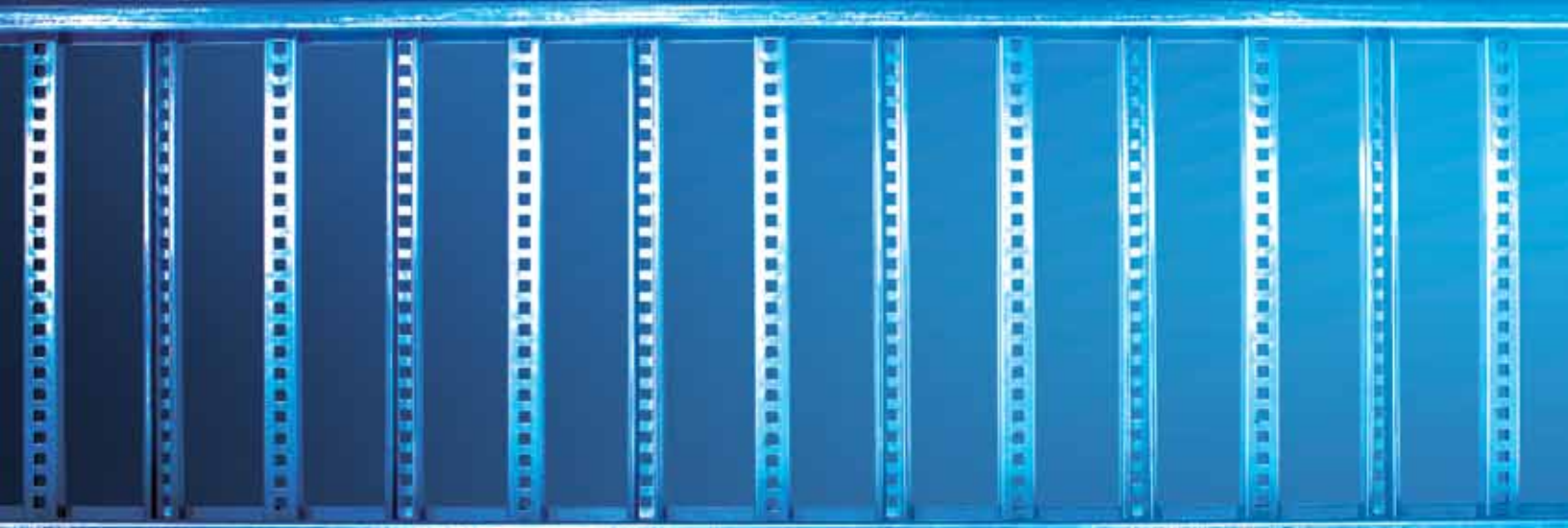

- **T&B Ladder Tray Systems**
 - Aluminum, steel and stainless steel cable tray
 - Large-radius and long support span cable tray
 - Nonmetallic cable tray
- **T&B One-Piece Tray and Channel Tray**
- **ExpressTray® Wire Basket Tray**
- **Superstrut® Metal Framing Channel and Accessories**
- **Complementary products including tray/teck cable termination products, grounding products, and more**
- **T&B Cable Tray designed and manufactured in Canada, with manufacturing facilities strategically located in Edmonton, Alberta, and in Saint-Jean-sur-Richelieu, Quebec**
- **Fast turnaround, custom delivery schedules, local services and support**
- **80% of products sold in Canada are also manufactured in Canada**

w w w . t n b . c a

• **Atlantic Provinces**
Tel.: (902) 450-1307
Toll Free: 1-877-862-4357

• **Quebec**
Tel.: (450) 466-1102
Toll Free: 1-800-465-1399

• **Ontario**
Tel.: (905) 635-7888
Toll Free: 1-877-291-7771

• **Manitoba/Saskatchewan**
Tel.: (604) 598-9811
Toll Free: 1-866-540-8220

• **Alberta**
Tel.: (780) 424-7092
Toll Free: 1-888-664-5666

• **British Columbia**
Tel.: (604) 598-9811
Toll Free: 1-866-540-8220

Thomas & Betts. Your best connection for innovative solutions.

Thomas & Betts

A Member of the ABB Group